

Weed Management in Organic Agriculture

Ted Radovich
Sustainable Farming Systems Laboratory
Department of Tropical Plant and Soil Sciences
University of Hawaii at Manoa
3190 Maile Way, St. John 102
Honolulu, Hawaii 96822
PHONE: 808-956-7909
FAX: 808-956-3894
www2.hawaii.edu/~theodore



College of Tropical Agriculture and Human Resources
University of Hawai'i at Mānoa

Web Resources

CTAHR COVER CROP DATABASE

<http://www2.ctahr.hawaii.edu/sustainag/Database.asp>

MANAGING COVER CROPS PROFITABLY (book)

www.sare.org/publications/covercrops/covercrops.pdf

STEEL IN THE FIELD (book)

<http://www.sare.org/publications/steel/index.htm>

FLAMING

<http://www.attra.org/attra-pub/flameweetveg.html>

LIVING MULCH IN HAWAII

<http://www2.hawaii.edu/~leary/a.htm>

WEED BIOCONTROL IN HAWAII & WEEDS AS RESOURCES

<http://www2.hawaii.edu/~theodore/Links.htm>



College of Tropical Agriculture and Human Resources
University of Hawai'i at Mānoa

Suppliers

Koolau Seed and Supply, Inc., 48-373G Kamehameha. Hwy, Kaneohe, HI 96744, 808-239-1280. *Cover crop seeds.*

United Agri Products (UAP) 96-1345 Waihona St. 808-454-0041
Various products

BEI 311 Pacific Street, Honolulu, HI 96817, 808.532.7400. *Various.*

Airgas/Gaspro Airgas Gaspro 2305 Kamehameha Hwy., Honolulu, HI 96819, (808) 842-2222.

Peaceful Valley Farm Supply, P.O. Box 2209, 125 Clydesdale Court, Grass Valley, CA 95945, (530) 272-4769. <http://www.groworganic.com>

Flame Engineering, Inc., P.O. Box 577, LaCrosse, Kansas 67548, 1-888-388-6724, <http://www.flameengineering.com>



College of Tropical Agriculture and Human Resources
University of Hawai'i at Mānoa

A Weed is...

Any plant that interferes with human welfare or activity, or is otherwise objectionable.



Plants Out Of Place (P.O.O.P Rule)



College of Tropical Agriculture and Human Resources
University of Hawai'i at Mānoa

Classification of Weeds

Broadleaf

Many of our annual weeds, growing points high above the ground, succulent growth more tender than grasses.

Legumes

Annual or perennial broadleaf plants that fix N gas from the air, and are more tolerant to poor soil conditions

Grasses/Sedges

Often strong perennials, growing points close to or below the ground, tough foliage with high silica content.



College of Tropical Agriculture and Human Resources
University of Hawai'i at Mānoa

Broadleaf



Spiny amaranth



Spanish needle



Common purslane



College of Tropical Agriculture and Human Resources
University of Hawai'i at Mānoa

Legumes



Japanese tea



Sleeping grass



Legume nodules



College of Tropical Agriculture and Human Resources
University of Hawai'i at Mānoa

Grasses and Sedges



California grass



Guinea grass



Bristly foxtail



Purple nutsedge



College of Tropical Agriculture and Human Resources
University of Hawai'i at Mānoa

Agricultural losses :

- Direct competition with crop
- Hosts to crop pathogens, nematodes
- Clog irrigation water
- Contaminate crop with seeds/parts
- Reduce access to field or pasture
- Poison livestock



College of Tropical Agriculture and Human Resources
University of Hawai'i at Mānoa

Superior light interception and use

- Rapid expansion of tall foliar canopy
- Climbing habit
- Rapid response to shading



College of Tropical Agriculture and Human Resources
University of Hawai'i at Mānoa

Superior reproductive ability

- Germinates under wide range of conditions
- Germination variable over time
- Rapidly reaches reproductive stage
- Self compatible
- Seed production high



College of Tropical Agriculture and Human Resources
University of Hawai'i at Mānoa

Alternate Hosts

Amaranth spp. hosts *Meloidogyne incognita*



College of Tropical Agriculture and Human Resources
University of Hawai'i at Mānoa

Allelopathy

Beneficial or harmful effects of one plant on another plant by the release of chemicals from plant parts by leaching, root exudation, volatilization, residue decomposition and other processes.



College of Tropical Agriculture and Human Resources
University of Hawai'i at Mānoa

**Come on, weeds
can't be all bad?**



College of Tropical Agriculture and Human Resources
University of Hawai'i at Mānoa

Weed Benefits

- Protect topsoil
- Conserve moisture
- Extensive root systems penetrate deep into the subsoil.
 - Improve crop root growth
 - Drainage
 - Accumulate nutrients from the subsoil, particularly trace elements, and transport them to the soil surface.
- Nurse crop
- Food and Shelter for beneficial organisms
- Food and Medicine for people
- Information about soil quality



College of Tropical Agriculture and Human Resources
University of Hawai'i at Mānoa

Food and Medicine for People

Visit website for Weeds as Resources: An African Example

Plant	Use
Amaranth	Leafy vegetable, grain
Spanish needle	Leafy vegetable, tonic, anti-inflammatory
Purslane	Salad green, grain, high Omega-3
Galinsoga spp.	Sap a first-aid wound treatment



College of Tropical Agriculture and Human Resources
University of Hawai'i at Mānoa

Weeds: How do we manage them?



College of Tropical Agriculture and Human Resources
University of Hawai'i at Mānoa

Integrated weed management

Basic Elements:

- **Focus on reducing populations below levels that cause damage.**
- **Multiple tactics employed in a compatible manner.**
- **Focus on multiple bottom line: economic, environmental and social sustainability.**



College of Tropical Agriculture and Human Resources
University of Hawai'i at Mānoa

Management Strategies

- **Prevention**
- **Cultural**
- **Mechanical**
- **Biological**
- **Benign neglect**



College of Tropical Agriculture and Human Resources
University of Hawai'i at Mānoa

Weed Prevention Strategies

1. Don't allow weeds to go to seed.



College of Tropical Agriculture and Human Resources
University of Hawai'i at Mānoa

Weed Seed Production

Weed Seed Bank

- Average number of seeds in soil is 30,000-350,000 weed seeds/m²
- 120 million-1.4 billion per acre.

Weed	Seed#/plant
<i>Amaranth</i>	235,000
<i>Lambsquarters</i>	100,000
<i>Crabgrass</i>	50,000
<i>Spurge</i>	3,000



College of Tropical Agriculture and Human Resources
University of Hawai'i at Mānoa

**“One year of seeding,
Seven years of weeding”**



College of Tropical Agriculture and Human Resources
University of Hawai'i at Mānoa

Critical period

- Generally vegetable crops are kept weed free during a critical weed-free period early in development.

- Critical periods:

 - ~3-5 weeks for transplants and grains.

 - > 5 weeks for direct seed veggies and veggies with small canopies or wide spacing.

 - Onions are kept weed free throughout growth.



College of Tropical Agriculture and Human Resources
University of Hawai'i at Mānoa

Weed Prevention Strategies

1. Don't allow weeds to go to seed.
2. Clean equipment before moving from infested field.
3. Buy uncontaminated crop seed from a reputable source.
4. Thoroughly compost (131 F for 3 days) manure and other residues that might contain seeds. Almost no seeds survive in chicken manure.
5. Filter surface water if possible.
6. Apply fertilizer and irrigation directly to the crop row if possible.
7. Work with your neighbors.



College of Tropical Agriculture and Human Resources
University of Hawai'i at Mānoa

Cultural Strategies

Crop selection and rotation

- Rotate weed-susceptible crops (carrots, onions, widely spaced crops) with suppressive crops such as sweet corn, pumpkin, sweet potatoes.
- Weed suppressive cover crops should be used in problem areas. Sudex, Buckwheat, Crotonaria, Cereal rye, Rape.
- Ground cover critical for weed suppression. Pay attention to cover crop pest problems and requirements. See CTAHR cover crop database: <http://www2.ctahr.hawaii.edu/sustainag/Database.asp>
- ***Managing Cover Crops Profitably***: Good survey of material available, seeding rates appear low for local conditions. www.sare.org/publications/covercrops/covercrops.pdf



College of Tropical Agriculture and Human Resources
University of Hawai'i at Mānoa

Cover Crops



Crotonaria
(Sunnhemp)



Ryegrass



Sudex



Buckwheat



College of Tropical Agriculture and Human Resources
University of Hawai'i at Mānoa

Cover Crops



Brassica mix



Oats



College of Tropical Agriculture and Human Resources
University of Hawai'i at Mānoa

Trial, N. Shore O'ahu (McHugh and Constantinides, 2007)

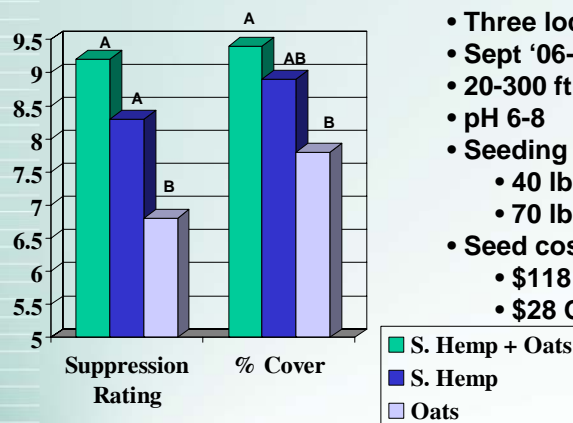

- Three locations
- Sept '06-Jan '07
- 20-300 ft elevation
- pH 6-8
- Seeding rate:
 - 40 lbs/ac SH
 - 70 lbs/ac Oats
- Seed cost:
 - \$118 lb/ac
 - \$28 Oats



College of Tropical Agriculture and Human Resources
University of Hawai'i at Mānoa

Cultural Strategies

Variety selection and spacing

- Choose crop varieties that are well adapted to your area.
- Plant at the best time of year for vegetative growth.
- Choose crop varieties with vigorous canopy development.
- Purchase high quality seed.
- Use transplants where possible.
- Space plants at the higher end of recommended density ranges.



College of Tropical Agriculture and Human Resources
University of Hawai'i at Mānoa

Cultural Strategies

Cover Crop Allelopathy

- Allelopathy is controversial as an effective weed suppressive strategy.
- Most consistently demonstrated with rye and correlated with DIBOA (2,4-dihydroxy-1,4-benzoxazin-3-one)
- Suggested strategy: seed at high density, irrigate until good cover established, drought-stress plants to increase DIBOA, kill early in development when DIBOA highest, do not incorporate residue.



College of Tropical Agriculture and Human Resources
University of Hawai'i at Mānoa

Cereal rye (*Secale cereale*)



College of Tropical Agriculture and Human Resources
University of Hawai'i at Mānoa

Mechanical Strategies

Cultivation Steel in the Field <http://www.sare.org/publications/steel/index.htm>

- Very important strategy relied on by many growers.
- Plant very straight, uniformly spaced rows to allow for close cultivation to the plants.
- Keep cultivation shallow to minimize weed seed germination.
- Cultivate weeds early (< 1 inch ideally) at ~50% field capacity.
- Push dirt into rows of long-stemmed plants to cover small weeds.



College of Tropical Agriculture and Human Resources
University of Hawai'i at Mānoa

Mechanical Strategies

Cultivation



College of Tropical Agriculture and Human Resources
University of Hawai'i at Mānoa

Flex Tine

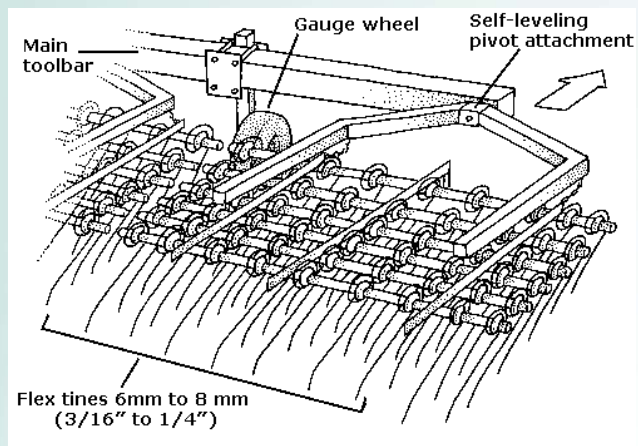

College of Tropical Agriculture and Human Resources
University of Hawai'i at Mānoa

Cultivator (high residue)

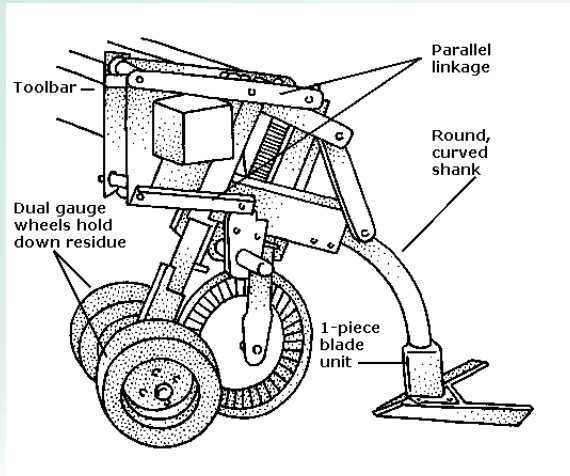

 College of Tropical Agriculture and Human Resources
University of Hawai'i at Mānoa

Spyders

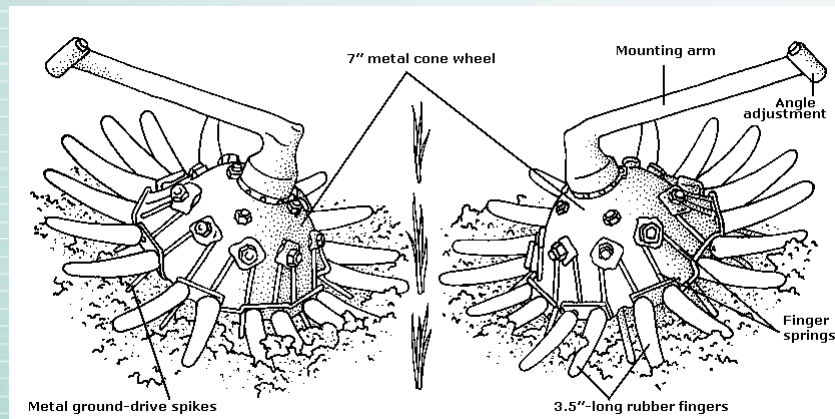

 College of Tropical Agriculture and Human Resources
University of Hawai'i at Mānoa

Basket weeders

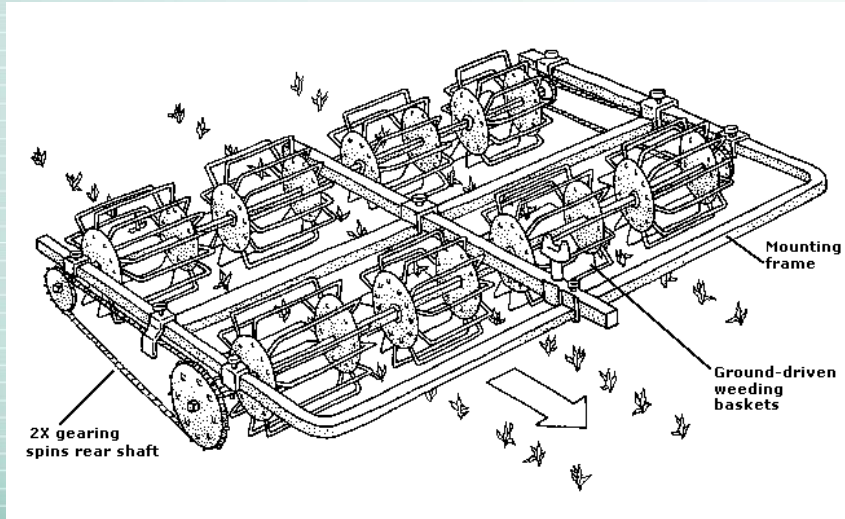

College of Tropical Agriculture and Human Resources
University of Hawai'i at Mānoa

Brush Weeder

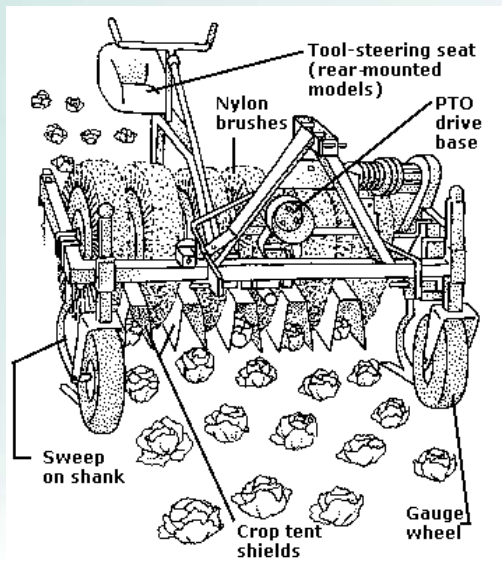

College of Tropical Agriculture and Human Resources
University of Hawai'i at Mānoa

Mechanical Strategies

Flaming

- **High temperatures burst cells (not burn plants).**
- **Weeds should be small (< 3”).**
- **Weeds should be well-watered, but with dry leaf surface.**
- **Flaming at night increases efficacy**



Mechanical Strategies

Flaming

- **Most effective on broadleaf weeds.**
- **Grasses more resistant.**
- **Can be done before (1-2 days) and after crop emergence.**
- **Tolerance of crops to flaming varies with species and size (see ATTRA document).**



Mechanical Strategies

Flaming

- Recommended rate = 18-27 pounds propane per acre.
- 1 gallon liquid propane = 4 pounds.
- 5-7 gallons of liquid propane per acre.



College of Tropical Agriculture and Human Resources
University of Hawai'i at Mānoa

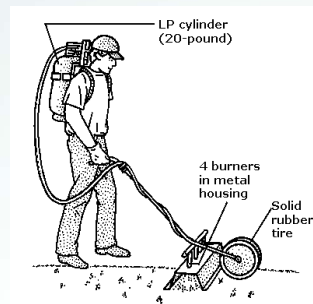

College of Tropical Agriculture and Human Resources
University of Hawai'i at Mānoa

Chemical Strategies

Organic herbicides

- Active ingredients are usually essential oils and/or acids. The most common:
 - Clove oil
 - Acetic acid
 - Citric acid
- These are contact herbicides, effective only on small weeds, and more effective on broadleaves than grasses.
- So far the economics are poor in the few studies done.
- Corn gluten meal is also used, primarily in turf
<http://wihort.uwex.edu/turf/CornGluten.htm>



College of Tropical Agriculture and Human Resources
University of Hawai'i at Mānoa

Clove Oil Based Herbicides



Photo courtesy Jari Sugano



College of Tropical Agriculture and Human Resources
University of Hawai'i at Mānoa

Stale seed bed technique

- This technique is used to exhaust the active seed bank in the first several inches of soil.
- The area is tilled, fertilized and irrigated to promote weed germination.
- Young weeds are killed mechanically.
- Weeds are allowed to flush again and killed.
- Seeds or transplants are placed in the field with minimal or no tillage.



College of Tropical Agriculture and Human Resources
University of Hawai'i at Mānoa

Mechanical Strategies

Mulch

- Plastic and organic mulches may be used.
- With organic mulches, light exclusion and persistence most important.
- In general, grasses persist the longest, legumes the shortest.
- Living mulches, if controlled properly, can increase soil moisture and bioactivity, reduce pest pressure and weed competition. See: <http://www2.hawaii.edu/~leary/a.htm>



College of Tropical Agriculture and Human Resources
University of Hawai'i at Mānoa

Mulch



Perennial peanut
in Waimanalo

Cover crop roller in Ohio



Sickle bar mower



Weeds imported with mulch



College of Tropical Agriculture and Human Resources
University of Hawai'i at Mānoa

Mechanical Strategies

Mulch

- Black plastic mulch extremely effective, and warms soil.
- Solarization to kill weed propagules with clear mulch is tricky: 1) Smooth bed; 2) Film must be against soil; 3) air temperatures > 90 F; 4) Plastic left for 4-6 weeks; 5) do not till more than 3 inches afterward.
- Solarization most effective when combined with other strategies.
- Other mulch colors may improve crop photosynthesis (Red) or disorient pests (Reflective)



College of Tropical Agriculture and Human Resources
University of Hawai'i at Mānoa

Mulch



Walk-behind mulch laying attachment

Woven mat in Kula



College of Tropical Agriculture and Human Resources
University of Hawai'i at Mānoa

Biological Control

- Insects
- Pathogens

See Biological Control article on Ted's resource page. <http://www2.hawaii.edu/~theodore/Links.htm>

- Domesticated Animals



Grazing cages by
Glenn Fukumoto

Kona

gfukumot@hawaii.edu



College of Tropical Agriculture and Human Resources
University of Hawai'i at Mānoa